

SPEC SHEET (FOR REFERENCE)	SHEET No.	Rev.	Page.
	G05026A	1	1 of 1

**TYPE:6PT1603P1T \* \***

CHIP SIZE	0.36 * 0.36mm
WAFER SIZE	6inch
POSSIBLE DIE PER WAFER	119,000pcs

Maximum Ratings (Ta=25°C)

Characteristics	Symbol	Ratings	Unit
Drain-source voltage	VDSS	-30	V
Gate-source voltage	VGSS	±8	V

WAFER PROBING SPEC (Ta=25°C)

No	MODE	LIMIT			UNIT	CONDITIONS
		MIN.	Typ	MAX.		
1	IGSS1			±500	nA	VGS=±8V VDS=0V
2	IDSS			-10	uA	VDS=-32V VGS=0V
3	BVDSS	-32			V	ID=-100uA
4	VTH	-0.65		-1.05	V	ID=-250uA
5	RDS(on)		3.2	5	Ω	VGS=-4.0V, ID=-100mA
6	Yfs	130			mS	VDS=-10V Id=-100mA

\*ESD Protected

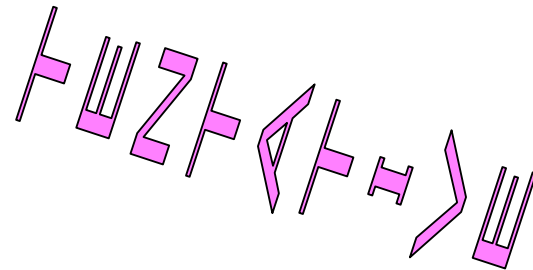
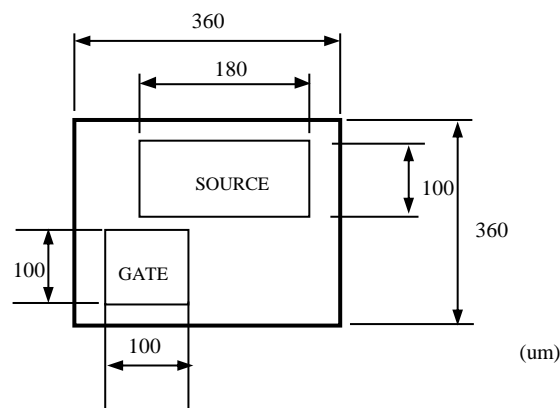

NOTE: